

PARTS MANUAL

**H190HD2, H210HD2, H230HD2,
H230HDS2, H250HD2, H280HD2
(J007)**

CUSTOMER EDITION

HYSTER

SECTIONS

1	FRAME
2	ENGINE ASSEMBLY
3	FUEL SYSTEM
4	ELECTRICAL SYSTEM
5	TRANSMISSION - STANDARD
6	TRANSMISSION - HEAVY DUTY
7	DRIVE AXLE
8	STEERING SYSTEM
9	BRAKE SYSTEM
10	HYDRAULIC SYSTEM
11	MAST-TWO STAGE LIMITED FREE-LIFT
12	MAST-THREE STAGE FULL FREE-LIFT
13	ATTACHMENTS
14	OPTIONS
15	FIELD CONVERSION KITS
16	NUMERICAL INDEX

This Parts Manual is divided into 16 major sections which are listed above. Quick reference to these sections can be made by placing the right thumb on the tab of the desired section, bending the book back and thumbing the pages to the corresponding tab.

**Thanks very much for your reading,
Want to get more information,
Please click here, Then get the complete
manual**

JustClickHere 

NOTE:

**If there is no response to click on the link above,
please download the PDF document first, and then
click on it.**

**Have any questions please write to me:
admin@servicemanualperfect.com**

TABLE OF CONTENTS

DESCRIPTION	PAGE
A	
AIR CLEANER ASSEMBLY	3-4
AIR COMPRESSOR	2-14
AIR COMPRESSOR COOLANT PLUMBING	2-17
AIR COMPRESSOR MOUNTING	2-16
AIR CONDITIONER	
CLIMATE CONTROL CAB	1-68
AIR CONDITIONER ASSEMBLY	
CLOSED CAB WITH AIRCO	1-56
AIR CONDITIONER FILTER AND COVER ASSEMBLY	
CLOSED CAB	1-52
AIR CONDITIONER SYSTEM	
CLIMATE CONTROL CAB	1-66
CLOSED CAB WITH AIRCO	1-53
AIR CONDITIONER SYSTEM ASSEMBLY	
WITH TWO-FAN CONDENSER SYSTEM - MCC	1-122
AIR CONDITIONING COMPRESSOR AND ATTACHING PARTS	1-58
AIR DRYER ASSEMBLY	9-26
AIR DRYER SYSTEM	
DRY BRAKE	9-24
AIR DUCT	
CLOSED CAB WITH AIRCO OR CLIMATE CONTROL	14-18
LOUVER, CLIMATE CONTROL CAB	1-64
AIR DUCT ASSEMBLY	
AIR CONDITIONING - CLOSED CAB WITH AIRCO	1-54
HEATER - CLOSED CAB WITHOUT AIRCO	1-44
AIR HEATER STARTING AID	2-18
AIR INTAKE CONNECTION	2-19
AIR INTAKE MANIFOLD	2-20
AIR INTAKE SYSTEM	3-2
AIR TRANSFER CONNECTION	2-21
ALTERNATOR AND MOUNTING	4-21
ALTERNATOR SUPPORT AND WATER INLET	2-22
ARMREST ASSEMBLY	1-84
AUXILIARY PUMP DRIVE	5-14
B	
BATTERY CABLES	
WITH AND WITHOUT DISCONNECT SWITCH	4-6
BELT TENSIONER	2-23
BRAKE ASSEMBLY	
DRY BRAKE	9-20
WET BRAKE - 425 SERIES DRIVE AXLE	9-12
WET BRAKE - 475 SERIES DRIVE AXLE	9-14
BRAKE PEDAL AND LINKAGE	9-2
BRAKE PEDAL ASSEMBLY	9-4
BRAKE SYSTEM	
DRY BRAKE	9-16
WET BRAKE	9-6

TABLE OF CONTENTS (continued)

DESCRIPTION	PAGE
BRAKE VALVE AND ATTACHING PARTS	
DRY BRAKE	9-18
WET BRAKE	9-10
C	
CAB	
CLOSED - PAGE 1 OF 2	1-18
CLOSED - PAGE 2 OF 2	1-20
OPEN - PAGE 1 OF 2	1-14
OPEN - PAGE 2 OF 2	1-16
CAB AND TILT CYLINDER MOUNTING	1-70
CAB ATTACHING PARTS	1-22
CAB DOOR	
LEFT HAND - CLOSED CAB	1-30
RIGHT HAND - CLOSED CAB	1-28
CAB MAIN DOOR WINDOW	
RIGHT AND LEFT HAND	1-34
CAB RECIRCULATING FAN	
CLOSED CAB	1-40
CAB SUNSHADE - REAR	
CLOSED CAB WITH AIRCO - OPTIONAL FOR CLOSED CAB WITHOUT AIRCO	1-26
CAB SUNSHADE - TOP	
CLOSED CAB WITH AIRCO - OPTIONAL FOR CLOSED CAB WITHOUT AIRCO	1-25
CAB TILT CYLINDER	1-76
CAB TILT PUMP	
ELECTRIC	1-80
CAB TILT PUMP ASSEMBLY	1-78
CAB WINDOWS INSTALLATION	
CLOSED CAB	1-32
CABIN HEATER PLUMBING	2-72
CAMSHAFT	2-24
CARRIAGE	
2 STAGE- DUAL FUNCTION - WITH FORK POSITIONER	13-28
2 STAGE- ISS - WITHOUT FORK POSITIONER, 3-FUNCTION	13-14
2 STAGE- ISS - WITHOUT FORK POSITIONER, 4, 5, 6-FUNCTION	13-16
2 STAGE- ISS - WITH INDIVIDUAL FORK POSITIONER, 4, 5, 6-FUNCTION	13-18
2 STAGE- ISS - WITH SIMULTANEOUS FORK POSITIONER, 4, 5, 6-FUNCTION	13-22
2 STAGE-STANDARD - WITHOUT FORK POSITIONER, 3-FUNCTION	13-4
2 STAGE-STANDARD - WITHOUT FORK POSITIONER, 4, 5, 6-FUNCTION	13-6
2 STAGE-STANDARD - WITH INDIVIDUAL FORK POSITIONER, 4, 5, 6-FUNCTION	13-8
2 STAGE-STANDARD - WITH SIMULTANEOUS FORK POSITIONER, 4, 5, 6-FUNCTION	13-10
3 STAGE-ISS - WITHOUT FORK POSITIONER	13-44
3 STAGE-ISS - INDIVIDUAL FORK POSITIONER	13-48
3 STAGE-ISS - SIMULTANEOUS FORK POSITIONER	13-52
3 STAGE-STANDARD	13-58
CARRIAGE ASSEMBLY	
2 STAGE- ISS	13-26
2 STAGE-STANDARD	13-12
CHARGE PUMP AND FILTER ASSEMBLY	5-16

TABLE OF CONTENTS (continued)

DESCRIPTION	PAGE
COMPRESSOR ASSEMBLY	1-60
CONDENSER	
CLOSED CAB WITH AIRCO	1-62
CONDENSER SYSTEM	
TWO-FAN SYSTEM - MCC	1-124
CONNECTING RODS AND PISTONS	2-26
CONTROL PANEL ASSEMBLY	
HEATER	4-12
HEATER AND AIR CONDITIONER	4-13
CONTROL VALVE	
PAGE 1 OF 4	6-28
PAGE 2 OF 4	6-29
PAGE 3 OF 4	6-30
PAGE 4 OF 4	6-32
CONVERTER	6-4
COOLANT HEATER STARTING AID	2-28
COOLING	2-2
COUNTERWEIGHT WITH LIFTING EYES	1-4
COUNTERWEIGHT WITHOUT LIFTING EYES	1-6
CRANKCASE BREATHER	2-29
CRANKSHAFT AND BEARINGS	2-30
CYLINDER BLOCK	2-32
CYLINDER HEAD	2-34
D	
DASH ASSEMBLY	
CLOSED CAB	1-41
DC-DC CONVERTER AND ATTACHING PARTS	14-9
DIFFERENTIAL AND CARRIER	
DRY BRAKE	7-4
WET BRAKE	7-8
DIRECTIONAL CONTROL VALVE ASSEMBLY	
FOUR-SECTION	13-33
THREE-SECTION	13-32
TWO-SECTION	13-31
DRIVE AXLE HOUSING AND ATTACHING PARTS	7-2
DRIVE GEAR	5-30
DRIVE PLATE	5-32
DRIVE TIRES AND WHEELS	
BRIDGESTONE	7-21
MICHELIN	7-22
TRELLEBORG - SOLID TIRE	7-20
TRELLEBORG	7-23
TRELLEBORG TR900	7-24
DRIVE TRAIN	6-5
E	
ELECTRIC HORN	4-9
ELECTRICAL SYSTEM	4-4

TABLE OF CONTENTS (continued)

DESCRIPTION	PAGE
EMPTY SEAT ENGINE SHUTDOWN	14-6
EMPTY SEAT ENGINE SHUTDOWN OVERRIDE	15-2
ENGINE BLOCK HEATER	2-10
ENGINE CONNECTION	6-8
ENGINE CONTROL MODULE	4-18
ENGINE COOLANT VENT	2-36
ENGINE MOUNT	2-12
ENGINE OIL COOLER	2-37
ETR MODULE WIRING	4-20
EXHAUST MANIFOLD	2-38
EXHAUST SYSTEM	2-8
EXTERIOR MIRRORS	14-5
F	
FAN DRIVE AND MOUNTING	2-39
FIRST SPEED CLUTCH ASSEMBLY	6-16
FLOOR MATS	1-24
FLOORPLATES	1-12
FLOW DIVIDER MANIFOLD	13-62
FLYWHEEL AND MOUNTING	
DRY BRAKES	2-41
WET BRAKES	2-42
FLYWHEEL HOUSING	2-44
FORK POSITIONING CYLINDER	13-34
FORKS	13-2
FORWARD AND REVERSE LEVER TO MONOTROL KIT	15-2
FORWARD CLUTCH	5-22
FORWARD CLUTCH ASSEMBLY	6-22
FREE-LIFT CYLINDER	12-12
FRONT FENDER LIGHTS	4-29
FRONT GEAR COVER	2-46
FUEL FILTER	3-8
FUEL FILTER PLUMBING	3-9
FUEL INJECTION PUMP	3-14
FUEL INJECTOR PLUMBING	3-16
FUEL INJECTORS	3-18
FUEL INLET FITTING	3-11
FUEL RAIL SYSTEM	3-12
FUEL SYSTEM	3-6
G	
GEAR CLUTCH INSTALLATION	5-18
H	
HAND PUMP	1-82
HEADER HOSE	
THREE STAGE FULL FREE-LIFT	13-42
TWO STAGE LIMITED FREE-LIFT	13-38
HEATED TOP WINDOW	
CLOSED CAB	14-14

TABLE OF CONTENTS (continued)

DESCRIPTION	PAGE
HEATER AND AIR DUCT	
CLOSED CAB WITHOUT AIRCO	1-42
HEATER ASSEMBLY	
CLOSED CAB WITHOUT AIRCO	1-46
HEATER HOSES	1-50
HEATER SYSTEM	
CLOSED CAB WITHOUT AIRCO	1-48
HOODS AND COVERS	1-8
HUB AND SHAFT ASSEMBLY	
DRY BRAKE	7-12
WET BRAKE - 425 SERIES	7-14
WET BRAKE - 475 SERIES	7-16
HYDRAULIC CONTROL VALVE	
DRY BRAKE, THREE FUNCTION - HIC MID-INLET BLOCK ASSEMBLY	10-44
WET AND DRY BRAKE, THREE AND FOUR FUNCTION - LIFT SECTION ASSEMBLY, LH	10-50
WET AND DRY BRAKE, THREE AND FOUR FUNCTION - TILT SECTION ASSEMBLY	10-52
WET AND DRY BRAKE, THREE AND FOUR FUNCTION - AUXILIARY SECTION ASSEMBLY	10-56
WET BRAKE, FOUR FUNCTION - LIFT SECTION ASSEMBLY, RH	10-54
WET BRAKE, THREE AND FOUR FUNCTION - HIC MID-INLET BLOCK ASSEMBLY	10-46
WET BRAKE, THREE AND FOUR FUNCTION - HIC, BRAKE/ACCUMULATOR BLOCK ASSEMBLY	10-48
HYDRAULIC CONTROL VALVE AND ATTACHING PARTS	
DRY BRAKE, THREE FUNCTION - PAGE 1 OF 2	10-40
DRY BRAKE, THREE FUNCTION - PAGE 2 OF 2	10-42
WET BRAKE, FOUR FUNCTION - PAGE 1 OF 2	10-32
WET BRAKE, FOUR FUNCTION - PAGE 2 OF 2	10-34
WET BRAKE, THREE FUNCTION - PAGE 1 OF 2	10-36
WET BRAKE, THREE FUNCTION - PAGE 2 OF 2	10-38
HYDRAULIC CONTROL VALVE ASSEMBLY	
DRY BRAKE, THREE FUNCTION	10-62
WET BRAKE, FOUR FUNCTION	10-60
WET BRAKE, THREE FUNCTION	10-58
HYDRAULIC CONTROLS	
JOYSTICK - FORK LIFT TRUCK	10-14
HYDRAULIC LEVERS	
FOUR-LEVER CONTROL PANEL - WITH CLAMPING	10-22
FOUR-LEVER CONTROL PANEL - WITHOUT CLAMPING	10-24
THREE-LEVER CONTROL PANEL	10-20
TWO-LEVER CONTROL PANEL	10-18
HYDRAULIC PUMP AND ATTACHING PARTS	
120CC, HEAVY DUTY TRANSMISSION	10-10
90CC, DRY BRAKE	10-4
90CC, HEAVY DUTY TRANSMISSION	10-8
HYDRAULIC SUPPLY AND RETURN	
FOUR FUNCTION CONTROL VALVE - FORK LIFT TRUCK, THREE FUNCTION, DF SSFP	10-66
FOUR FUNCTION CONTROL VALVE - FORK LIFT TRUCK, FOUR/FIVE/SIX FUNCTION	10-67
FOUR FUNCTION CONTROL VALVE - WITHOUT LIFT ACCUMULATOR	10-68
FOUR FUNCTION CONTROL VALVE - WITH LIFT ACCUMULATOR	10-69
THREE FUNCTION CONTROL VALVE - WITHOUT LIFT ACCUMULATOR	10-64

TABLE OF CONTENTS (continued)

DESCRIPTION	PAGE
THREE FUNCTION CONTROL VALVE - WITH LIFT ACCUMULATOR	10-65
HYDRAULIC TANK AND ATTACHING PARTS	10-2
I	
INDICATOR DISPLAY AND CONTROLS	4-10
INDUCTIVE TRANSMITTER	6-14
INNER MAST	11-6
INSULATION MATS AND AIR DUCT	
CLOSED CAB WITH AIRCO OR CLIMATE CONTROL	14-16
J	
JOYSTICK ASSEMBLY	
FORK LIFT TRUCK	10-16
L	
LABELS	
HYDRAULIC CONTROLS	1-92
MAIN	1-88
LIFT	11-8
LIFTING BRACKETS AND MOUNTING	2-48
LIFTING EYES	14-2
LIGHT SWITCHES	4-14
LIGHTS	
DIRECTIONAL AND MARKER	4-30
WORK - HALOGEN	4-120
WORK - HID	4-121
LOAD BACKREST	1-3
LOCKOUT LEVER	4-8
LOUVER - HEAVY DUTY AIRCO	15-2
LOW CLUTCH	5-26
LUBRICATING OIL PUMP	2-50
M	
MAIN LIFT CYLINDER	11-12
MAP READING LIGHT	
CLOSED CAB	14-7
MAST ASSEMBLY	
PAGE 1 OF 3	12-4
PAGE 2 OF 3	12-6
PAGE 3 OF 3	12-8
MAST INSTALLATION	11-2
MAST WORKLIGHTS	4-118
MONOTROL PEDAL ASSEMBLY	3-22
MONOTROL TO FORWARD AND REVERSE LEVER KIT	15-2
O	
OIL DIPSTICK	6-15
OIL FILTER	2-51
OIL LEVEL GAUGE	2-52
OIL PAN	2-54

TABLE OF CONTENTS (continued)

DESCRIPTION	PAGE
OUTER MAST	11-4
OUTPUT FLANGE	5-36
OUTPUT SHAFT	5-34
P	
PARK BRAKE	
WET BRAKE	7-18
PARK BRAKE KITS	15-2
PIVOT ARM ASSEMBLY	1-86
POWER TAKE-OFF	6-7
PRESSURE FILTER	6-13
PRESSURE OIL PUMP	6-6
PRESSURE REGULATOR	6-33
R	
RADIATOR ASSEMBLY	2-4
OPTIONAL CONFIGURATION	2-6
RADIO CONSOLE AND ATTACHING PARTS	
CLOSED CAB ONLY	1-126
RAIN TOP	
OPEN CAB	14-20
REAR GEAR HOUSING	2-56
REAR WORK LIGHTS	4-28
RELAYS AND FUSES	4-24
REMOTE FUEL FILTER	3-10
RETROFIT KITS	15-2
REVERSE AND SECOND CLUTCH	5-24
REVERSE CLUTCH ASSEMBLY	6-24
REVERSE IDLER SHAFT	5-20
ROCKER LEVERS	2-58
S	
SEAT ASSEMBLY	
AIR SUSPENSION	1-108
DELUXE HEATED	1-120
DELUXE SUSPENSION	1-116
MECHANICAL AND AIR SUSPENSION	1-105
MECHANICAL SUSPENSION	1-112
SUSPENSION - WITH FABRIC COVER (→ 3/2010)	1-94
SUSPENSION - WITH FABRIC COVER (3/2010 →)	1-98
SUSPENSION - WITH VINYL COVER	1-102
SECOND 12V SOCKET OPTION	14-10
SECOND SPEED CLUTCH ASSEMBLY	6-18
SIDE-SHIFT CYLINDER	
TWO STAGE LIMITED FREE-LIFT - DUAL FUNCTION WITH FORK POSITIONER	13-36
TWO STAGE LIMITED FREE-LIFT AND THREE STAGE FULL FREE-LIFT	13-56
STARTER MOTOR	4-22
STEER AXLE	8-2
STEER COLUMN ASSEMBLY	8-16
STEER CYLINDER	8-6

TABLE OF CONTENTS (continued)

DESCRIPTION	PAGE
STEER TIRES AND WHEELS	
BRIDGESTONE	8-9
MICHELIN	8-10
TRELLEBORG - SOLID TIRE	8-8
TRELLEBORG	8-11
TRELLEBORG TR900	8-12
STEERING COLUMN	8-18
STEERING CONTROL UNIT ASSEMBLY	8-20
STEERING HOSES AND ATTACHING PARTS	8-14
STORAGE BOX	
CLOSED CAB	14-21
STROBE LIGHT	
WITH CONDENSER	4-32
WITHOUT CONDENSER	4-31
SUSPENSION KIT ASSEMBLY	1-118
T	
TAIL LIGHT ASSEMBLY	4-27
TELEMETRY KITS	15-2
THERMOSTAT	2-60
THIRD CLUTCH	5-28
THIRD SPEED CLUTCH ASSEMBLY	6-20
THREE-POINT SEAT BELT	14-23
THROTTLE AND INCHING SENSORS	3-24
THROTTLE PEDAL LINKAGE	3-20
TILT CYLINDER ASSEMBLY	10-30
TILT CYLINDER ATTACHING PARTS	
→ 11/2012	10-26
11/2012 →	10-28
TILT PLATFORM ASSEMBLY	1-74
TORQUE CONVERTER ASSEMBLY	5-4
TORQUE CONVERTER COOLER PLUGS	2-61
TORQUE CONVERTER HOUSING AND ATTACHING PARTS	5-2
TRAINING SEAT	
CLOSED CAB	14-8
TRANSMISSION CASE	5-8
TRANSMISSION CONTROL	4-16
TRANSMISSION CONTROL VALVE	5-10
TRANSMISSION DIAGNOSTICS INTERFACE CABLE	14-22
TRANSMISSION HOUSING	
PAGE 1 OF 2	6-10
PAGE 2 OF 2	6-12
TRANSMISSION MOUNTING AND HOSES	5-6
TURBINE SHAFT AND STATOR SUPPORT	5-12
TURBOCHARGER	2-62
TURBOCHARGER PLUMBING	2-64
U	
UNIVERSAL SHAFT	5-38

TABLE OF CONTENTS (continued)

DESCRIPTION	PAGE
V	
VALVE COVER	2-66
VALVE TAPPETS	2-67
VARIABLE ALARM	14-4
VIBRATION DAMPER	2-68
W	
WATER OUTLET CONNECTION	2-69
WATER PUMP	2-70
WATER PUMP DRIVE	2-71
WINDOW WIPER SYSTEM	
REAR AND ROOF WIPER KITS - AND FRONT WIPER OPTIONS	1-38
WASHER BOTTLE KIT	1-36
WIRE HARNESS	
ARMREST	4-34
BACK-UP ALARM	4-37
BRAKE TEMPERATURE	4-86
CAB LIGHTS	4-38
CAB REAR LIGHTS	4-89
CAB SIDE CONSOLE, HEAVY DUTY TRANSMISSION - PAGE 1 OF 5	4-70
CAB SIDE CONSOLE, HEAVY DUTY TRANSMISSION - PAGE 2 OF 5	4-72
CAB SIDE CONSOLE, HEAVY DUTY TRANSMISSION - PAGE 3 OF 5	4-76
CAB SIDE CONSOLE, HEAVY DUTY TRANSMISSION - PAGE 4 OF 5	4-80
CAB SIDE CONSOLE, HEAVY DUTY TRANSMISSION - PAGE 5 OF 5	4-82
CAB SIDE CONSOLE, STANDARD TRANSMISSION - PAGE 1 OF 5	4-54
CAB SIDE CONSOLE, STANDARD TRANSMISSION - PAGE 2 OF 5	4-56
CAB SIDE CONSOLE, STANDARD TRANSMISSION - PAGE 3 OF 5	4-60
CAB SIDE CONSOLE, STANDARD TRANSMISSION - PAGE 4 OF 5	4-64
CAB SIDE CONSOLE, STANDARD TRANSMISSION - PAGE 5 OF 5	4-66
CAB TILT	4-50
CAB UNDERFLOOR	4-51
CLOSED CAB	4-40
FRONT END	4-92
FRONT LIGHTS	4-87
MAST LIGHT EXTENSION - 5310MM LIFT HEIGHT AND HIGHER	4-91
MAST WORK LIGHT	4-88
OPEN CAB	4-43
REAR WIPER EXTENSION - CLOSED CAB	4-44
SIDE AND INDICATOR LIGHTS	4-45
STEER COLUMN	4-46
TAIL LIGHTS	4-90
TWO STAGE LIMITED FREE-LIFT	4-85
WASH PUMPS - CLOSED CAB	4-47
WIRE HARNESS (CHASSIS)	
HEAVY DUTY TRANSMISSION - PAGE 1 OF 3	4-106
HEAVY DUTY TRANSMISSION - PAGE 2 OF 3	4-110
HEAVY DUTY TRANSMISSION - PAGE 3 OF 3	4-114
STANDARD TRANSMISSION - PAGE 1 OF 3	4-94
STANDARD TRANSMISSION - PAGE 2 OF 3	4-98

TABLE OF CONTENTS (continued)

DESCRIPTION	PAGE
STANDARD TRANSMISSION - PAGE 3 OF 3	4-102
WIRE HARNESS AND SWITCH ASSEMBLY	
MONOTROL PEDAL	4-48
WIRE MESH ROOF PROTECTION	14-12

ABBREVIATIONS QUICK REFERENCE SHEET

Listed below are abbreviations used in parts manuals to denote the following expressions:

TERM	DEFINITION	TERM	DEFINITION
Amp	Amperes	FRE	Freezer Environment
AR	As Required	in.	inches
BDI	Battery Discharge Indicators	LPG	Liquefied Petroleum Gas
BWI	Brush Wear Indicator	MAP	Manifold Absolute Pressure
CE	Communicator End	mm	millimeters
CRE	Corrosive Environment	MSTS	Microprocessor Spark Timing System
D/B	Date Break	NPT	National Pipe Threads
dbA	Decibel "A" Scale	O/S	Oversize
DE	Drive End	PTO	Power Take Off
ECH	Empty Container Handler	RPM	Revolutions per Minute
ECH-3	Empty Container Handler - 3 High Stacking	S/N	Serial Number
ECH-4	Empty Container Handler - 4 High Stacking	TMM	Truck Management Module
ECH-5	Empty Container Handler - 5 High Stacking	UL Type D	Diesel-Powered Safety Rating
ECH-6	Empty Container Handler - 6 High Stacking	UL Type DS	Diesel-Powered Safety Rating
ECH-7	Empty Container Handler - 7 High Stacking	UL Type E	Battery-Powered Safety Rating
ECM	Electronic Control Module	UL Type EE	Battery-Powered Safety Rating
ECN	Engineering Change Notice	UL Type ES	Battery-Powered Safety Rating
EEPROM	Electrically Erasable Programmable Read Only Memory	UL Type G	Gasoline-Powered Safety Rating
EPA	US Environmental Protection Agency	UL Type GS	Gasoline-Powered Safety Rating
EPROM	Electrically Programmable Read Only Memory	UL Type LP	Gas-Powered Safety Rating
		UL Type LPS	LP Gas-Powered Safety Rating
		U/S	Undersize
		UL	Underwriters Laboratory
		V	Volts

HOW TO USE THE ILLUSTRATED PARTS MANUAL

This parts manual describes and illustrates assemblies, subassemblies, and detail parts needed for service replacement.

The different constructions are indicated by keys and footnotes. The callouts correspond to descriptions found on the next page.

HYSTER UNIT CODE D001 NORTH AMERICA 06/2001

TABLE OF CONTENTS

DESCRIPTION	PAGE
AIR INTAKE AND FILTER DIESEL (⇒ D/B 11/98)	3-22
AIR INTAKE AND FILTER DIESEL (D/B 11/96 ⇒)	
AIR INTAKE AND FILTER GASOLINE AND LPG	
ALTERNATOR GASOLINE, LPG, AND DIESEL	
ALTERNATOR TYPES GS, LPS, AND DS	
AUXILIARY FUNCTION TUBE TWO AND THREE STAGE FULL F	

SECTION 13 NUMERICAL INDEX

PART NO.	PAGE NO.	ITEM NO.	PART NO.	PAGE NO.	ITEM NO.	PART NO.	PAGE NO.	ITEM NO.	PART NO.	PAGE NO.	ITEM NO.
142	3-4	19	10-13	25		11-27	29	12-31	12		
12445	3-32	19	10-17	6		11-31	25	16719	3-36	5	
	3-34	1	10-27	11		11-32	37	16751	3-16	27	
			11-11	6	16485	8-4	29	16849	3-34	21	
			12-21	11		8-4	45		3-38	20	
			14	13		8-8	34	16863	3-28	17	
			12	6		9-7	9	16865	3-6	18	
			3	17		9-7	19		4-27	41	
			9	10		9-11	9	16882	9-7	30	
			23	46		9-11	17		9-11	27	
			27	46		10-9	21		10-10	36	
			26	14		10-9	28		10-13	32	
			28	14		10-13	16		11-7	24	
			50	14		11-7	19		11-9	17	

SECTIONS

- 1
- 2
- 3
- 4
- 5 BRAKE/ACC
- 6
- 7 MAST-TWO STAG
- 8 MAST-THREE ST
- 9 MAST-TWO ST
- 10
- 11

TRANSMISSION HOUSING ⇒ S/N D001H-2628

KEY:
A: Diesel
B: Gasoline and LPG

ITEM	PART NO.	DESCRIPTION	QTY	
			A	B
1	202547	Transmission	1	1
2	2023329	Transmission	1	1
3	2021670	Case	2	2
4	2023418	Bearing Cap	4	4
5	296429	Washer	4	4
6	293947	Bolt	1	1
7	2021390	Cover	2	2
8	1371656	Colter Pin	4	4
9	2021915	O-Ring	1	1
10	2021329	Plug	4	4
11	2021675	Housing	22	22
12	2021336	Pin	39	39
13	287860	Lockwasher	1	1
14	292682	Hydraulic Pump ⇒ Figure 5-3	1	1
15	2021345	Gasket	1	1
16	214364	Bolt	8	8
17	296418	Washer	1	1
18	2021388	Temperature Switch	1	1
19	2021389	Breather	9	9
20	2021383	Dipstick	9	9
21	292515	Bolt	2	2
22	136692	Nut	3	3
23	292527	Bolt	3	2
24	292531	Capscrew	4	4
25	292583	Lockwasher	4	4
26	293637	Bolt	4	4
	296420	Washer	1	1
	996403	Transmission Kit (Includes Item 7)	1	1
	996405	Transmission Kit (Includes Item 14)	1	1

This Parts Manual is divided into 11 major sections which are listed above. Quick be made by placing the right thumb on the tab of the desired section, bending the pages to the corresponding tab.

© Copy Right Date HYSTER COMPANY See Service Manual for service procedures. 5-15

HP990004

HOW TO FIND THE DESIRED PART NUMBER

WHEN THE PART NUMBER AND THE NEXT HIGHER ASSEMBLY IS NOT KNOWN:

1. Determine the function and application of the part required. Turn to the Sections Page. Choose the general area of reference most likely to include the part.
2. Turn to the section you chose. Use the Section Table of Contents to determine the assembly which would normally contain the part required. Then locate the part on the assembly breakdown page.

WHEN THE PART NUMBER IS NOT KNOWN AND THE NEXT HIGHER ASSEMBLY IS KNOWN:

3. Determine the assembly the required part is used on. Turn to the Table of Contents (Page i).
4. Locate the assembly the required part is used on and turn to the page indicated for that assembly. Then locate the part on the assembly breakdown page.

WHEN THE PART NUMBER IS KNOWN:

5. Use the Numerical Index (Page 16-1) to find the part number. Turn to the page listed and locate the part as indicated by the item number.

GENERAL:

The assembly breakdowns include part numbers, descriptions, quantities required, keys and footnotes to help in selecting correct parts.

6. Parts Supersession Information. Part numbers that have this history will be displayed in the parts list in the order that they were superseded (from oldest to newest). The superseded part numbers will be shown with a line through them.

Five periods in the PART NO. column (.) indicate that the part is either *Not Serviced Separately* or there is a reference to another figure. A figure reference is denoted by a pointing hand followed by a figure number in the DESCRIPTION column (☞ Figure 10)

7. Keys are used to show two or more similar assemblies, RH and LH assembly parts, etc. Select the appropriate key, "A", "B", "C", "D", or "E" and the corresponding quantity column to find the required parts. Two periods in the QTY column (..) indicate that the part is not used for that assembly.
8. Indented descriptions under the DESCRIPTION column are used to indicate assemblies and

subparts of assemblies. In the example on the previous page, *BEARING CAP* (Item 2) is a subpart of the major assembly *CASE*.

9. Quantities shown are for one assembly. The quantities of the subpart *BEARING CAP* are indicated as two and two. This means two per *CASE* assembly.
10. Serial number breaks identify the most current parts information and are shown as follows:
 - **S/N D001H2628**
Indicates last serial number affected.
 - S/N D001H2629** →
Indicates the first serial number affected.
 - S/N D001H1553** ↔ **S/N D001H3291**
Indicates a range of serial numbers affected.

ECN numbers for pending serial numbers are shown to allow for the inclusion of the most current parts information and are identified as follows:

→ **S/N Pending Per ECN 63243**

Indicates a pending serial number for last unit affected.

S/N Pending Per ECN 63243 →

Indicates a pending serial number for first unit affected.

Date breaks are used to indicate when a change occurred but a subsequent serial number break was not recorded. This is an arbitrary date usually based on the ECN release and are identified as follows:

→ **D/B 3/00**

Indicates that a change occurred sometime within that month for the item affected.

D/B 3/00 →

Indicates that a change occurred sometime within that month for the item affected.

D/B 3/00 ↔ **D/B 4/00**

Indicates a range of production dates of the item affected.

Contact your local dealer for Hyster lift trucks for serial number information for items with a ECN or a date break.

ORDERING PARTS:

When ordering replacement parts, give the unit serial number, part number, name of part and quantity required.

For any further information on parts, service, or ordering, consult your local dealer for Hyster lift trucks.

IDENTIFICATION OF TRUCK SERIAL NUMBERS

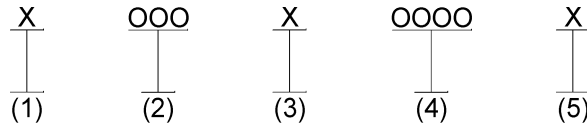

- (1) and (2) The first letter and three numbers indicate the truck unit code.
- (3) The second letter indicates the plant of manufacture.
- (4) The four or five digit number indicates the production sequence number of the truck.
- (5) The final letter indicates the year of manufacture starting with "A" in 1957, 1980, and 2003. The letters "I", "O", and "Q" will not be used.

For pending serial numbers contact your local dealer for Hyster lift trucks.

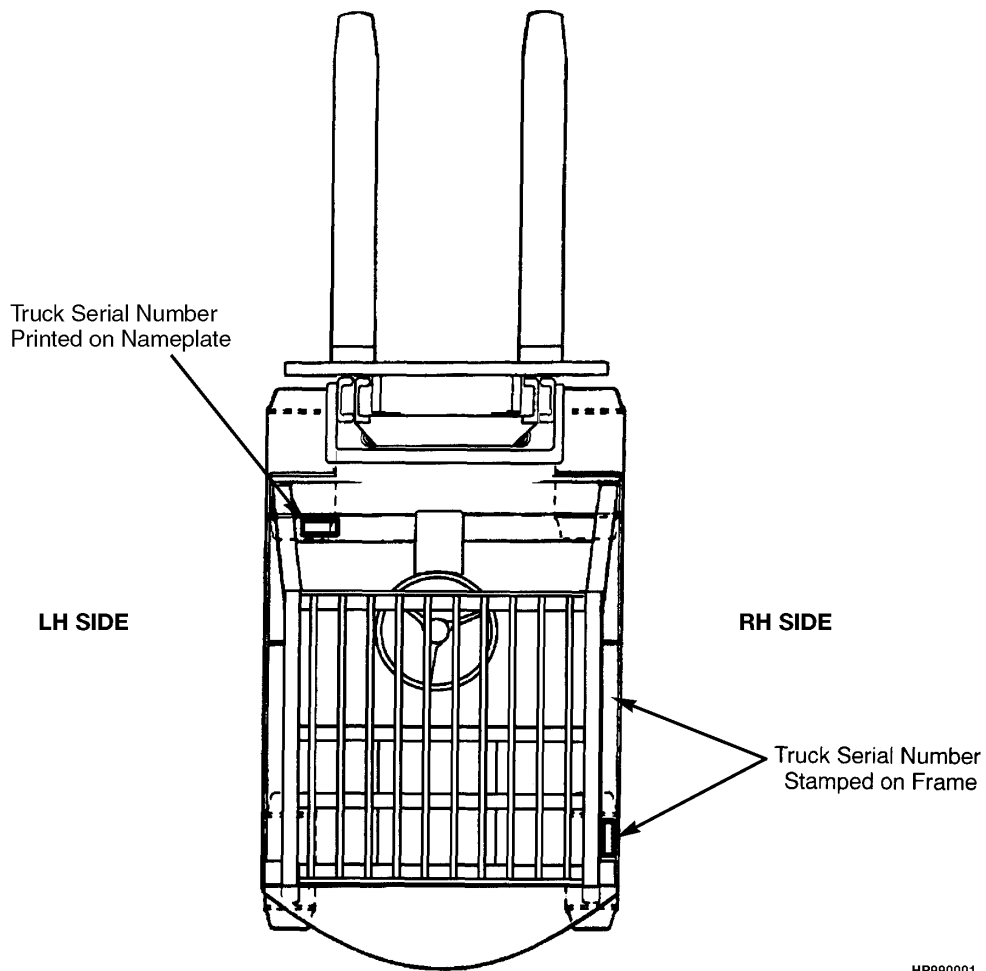

HP990001

Parts referred to in this book as right or left hand parts are in accordance with the illustration above.

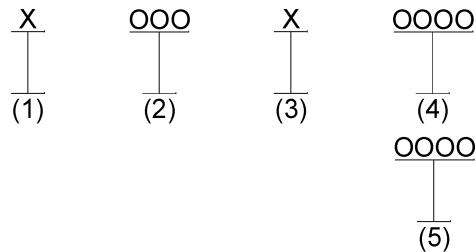
IDENTIFICATION OF MAST SERIAL NUMBERS

- (1) and (2) The first letter and number indicates the mast unit code.
- (3) The second letter indicates the plant of manufacture.
- (4) The four or five digit number indicates the production sequence number of the mast.
- (5) Carriage travel in millimeters stamped just below the serial number.

Mast Group identification consists of mast unit code (1) and (2) plus carriage travel (5).

For pending production sequence numbers contact your local dealer for Hyster lift trucks.

LIFT EQUIPMENT IDENTIFICATION

1. Fork part number, capacity rating, plant code letter, and date of manufacture are stamped approximately six inches below the top of most forks.
2. The carriage group number is stamped on the right hand side of the top crossmember (pin type) or on the back of the right hand end of the bottom crossmember (hook type). A date code has two letters in line with or below the carriage group number.
3. The mast identification number has a unit code, a letter indicating the plant of manufacture, and a serial number. Underneath the production sequence number is a four digit number that indicates the carriage travel in millimeters.
4. Tilt and lift cylinder group numbers are stamped on the cylinder shell.

Always refer to the group, serial, or part number when ordering service parts.

Modification of masts and carriages by SPED (Special Products Engineering Department) are identified by a model prefix code beginning with the letter "S". contact your dealer for Hyster lift trucks for information on these assemblies.

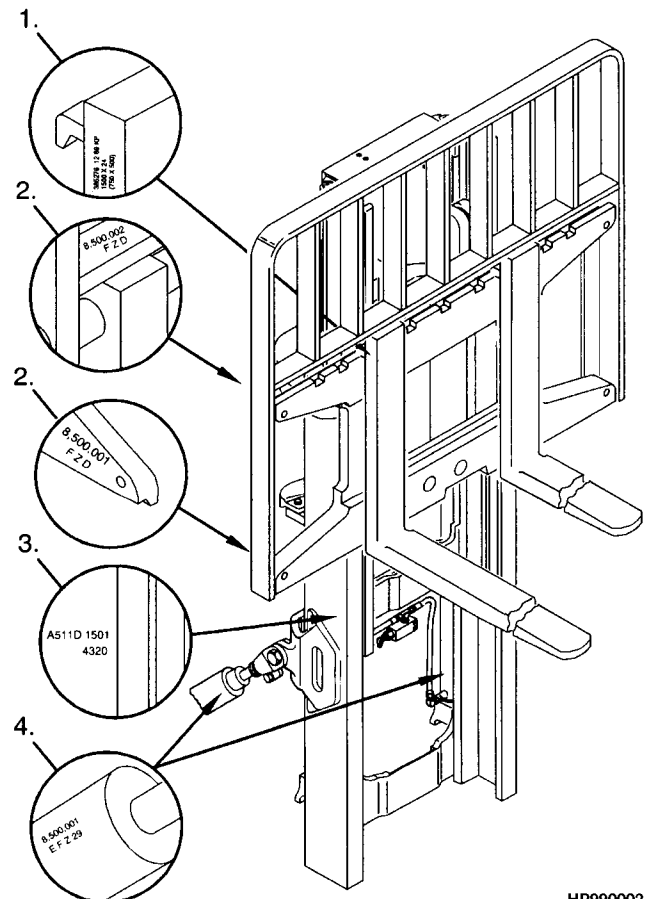

HP990002